

SL

Screen-Less Granulators

Mod. SL-1C

Mod. SL-2C

Mod. SL-3C

Mod. SL-4C

Caratteristiche tecniche

- Realizzati per applicazioni stampaggio tecnico (materozze)
- Basso numero di giri del rotore (25 RPM)
- Quattro modelli base
- Piastra magnetica, integrata nella tramoggia, per evitare che parti metalliche entrino in camera di taglio
- Apertura rapida e facilità di pulizia
- Trasmissione con giunti anti-stress
- Configurazione albero rotore con doppio cuscinetto

Technical data

- Designed for technical moulding applications (sprues and runners)
- Slow rotor speed (25 RPM)
- Four standard models
- High intensity magnetic trap, integral to the feed hopper, to ensure no metal parts reach the cutting chamber
- Quick opening and easy cleaning
- Anti-stress shaft rotation transmission
- Double-bearing shaft configuration



applications

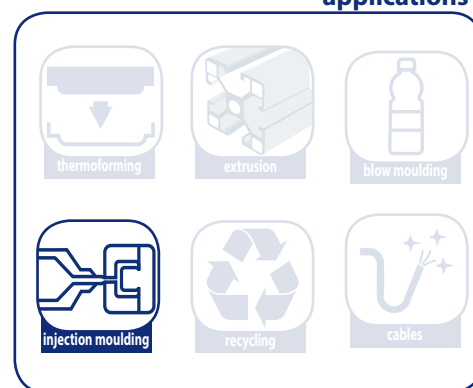

cmg-granulators.com

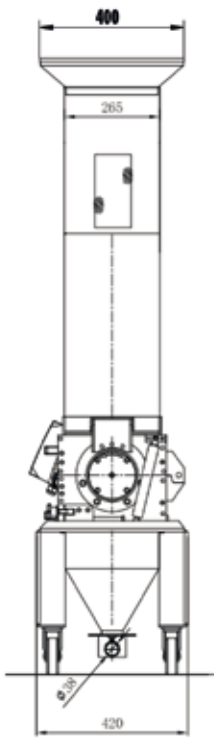

Vista laterale

Lateral view

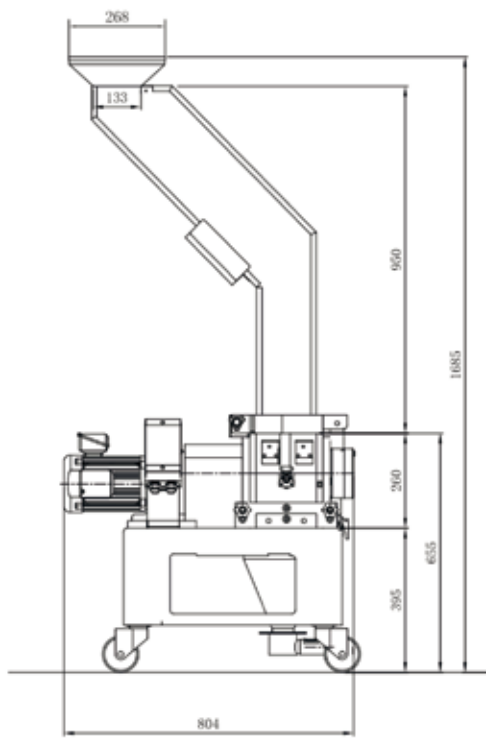

SL-1C

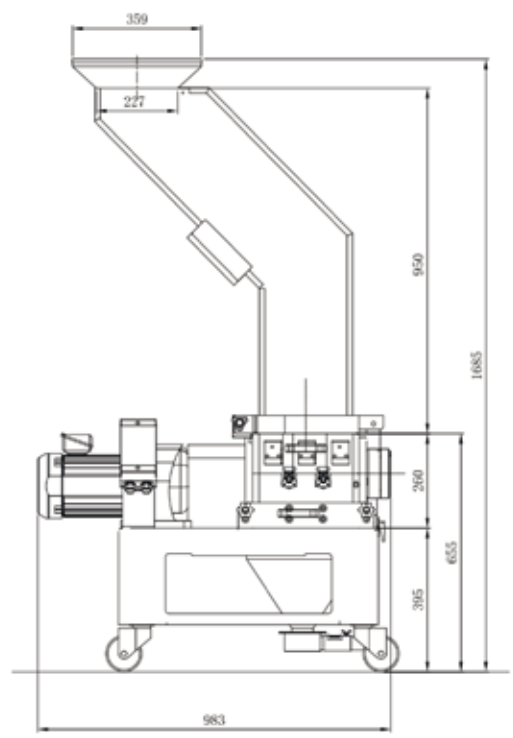



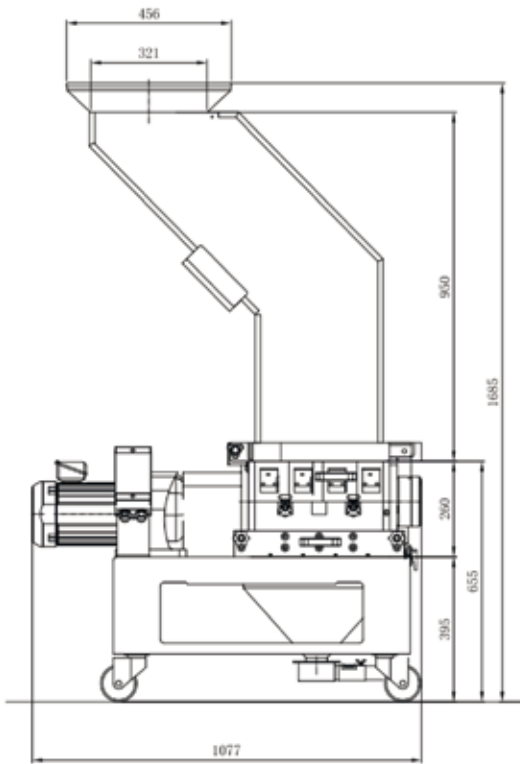

SL-2C

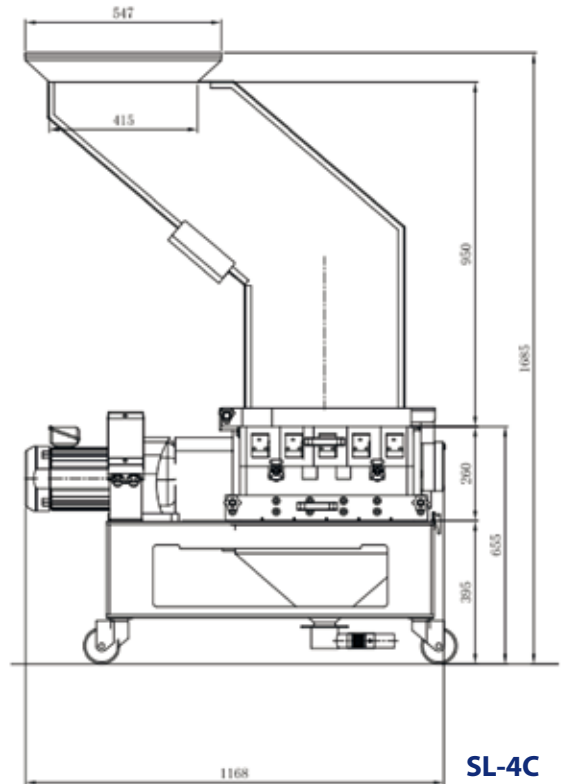

SL-3C



SL-4C

	 mm	MAIN CUTTER	SECTOR ELEMENT	 mm	 RPM	 KW	 Kg/H
SL-1C	268X400	1	2	268	25	0,75	5
SL-2C	359X400	2	3	268	25	1,5	10
SL-3C	456X400	3	4	268	25	1,5	15
SL-4C	547X400	4	5	268	25	1,5	20