

G 35

Granulators

Mod. G35-60

Caratteristiche tecniche

- Idonei per soffiaggio, iniezione e riciclo
- Tramoggia ribaltabile con meccanismo per una facile pulizia e manutenzione
- Camera di taglio con dischi e piastre laterali resistenti all'usura
- Taglio a "forbice" con lame regolabili per ridurre il consumo di energia e la formazione di calore e polvere
- Configurati per tutte le tipologie di evacuazione del macinato
- Sicurezze conformi alle normative CE
- Camera di taglio a sviluppo super tangenziale
- Lama rotante con alta inclinazione
- Assenza di polvere ed alta efficienza energetica
- Lame fisse e mobili a doppia inclinazione









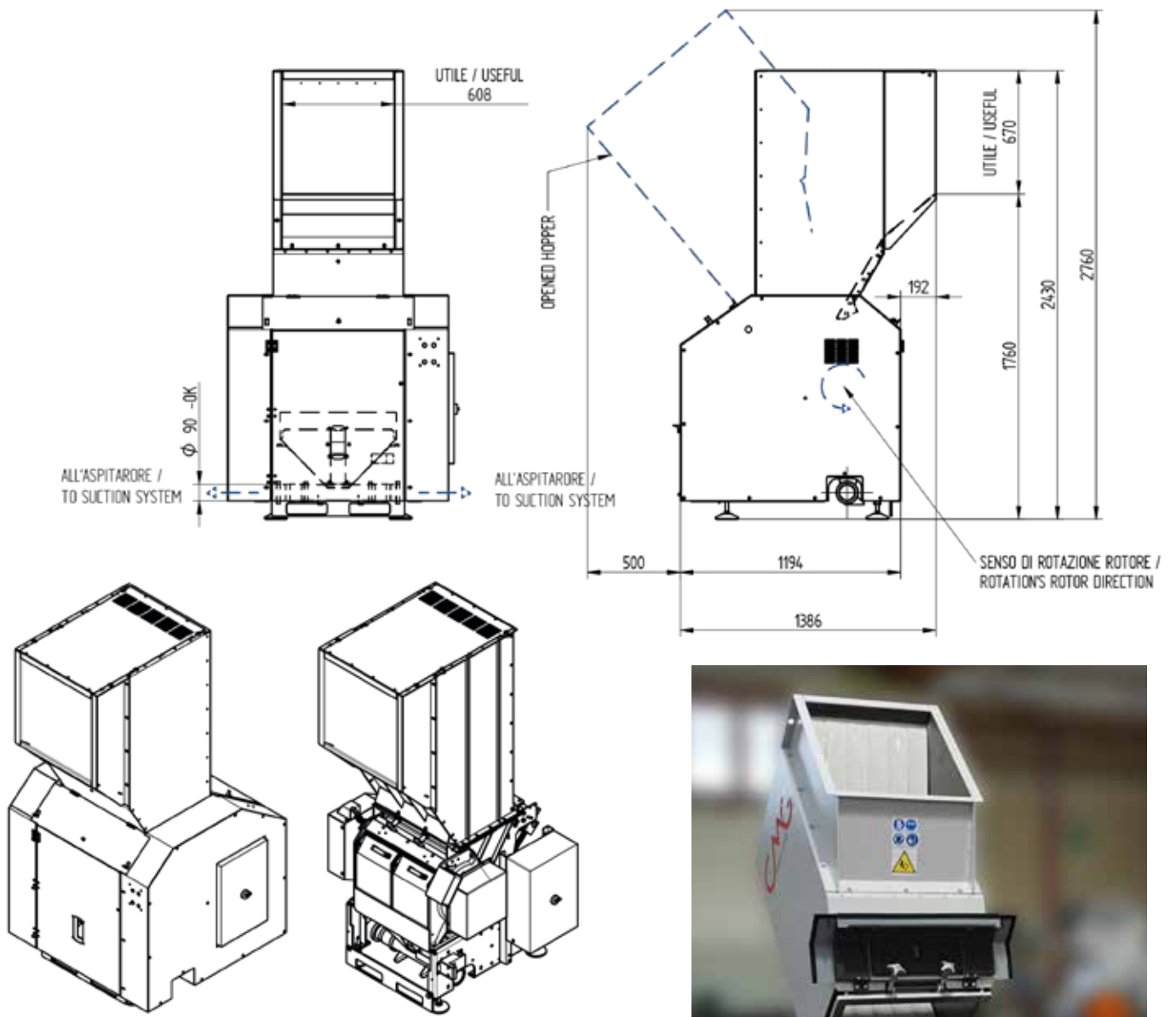

Technical data

- Suitable for blow moulding, injection moulding and recycling applications
- Tilting hopper with screw jack mechanism for easier cleaning and maintenance
- Cutting chamber with discs and plates wear resistant
- Advanced "Scissor" cutting action with adjustable rotor blades, reduces energy consumption, heat and dust generation
- Suitable for all kind of regrind evacuation systems
- Safety complies with CE standard
- Super tangential cutting chamber
- High inclination rotating knife
- No dust and energy high efficiency
- Double angle cut for fixed and rotor blades

applications





	 mm	 n°	 n°	 mm	 RPM	 Ø mm	 KW	 Kg/H
G35-60	608x660	3	2	350	450	8	11 (15-18,5-22)	300-500



cmg-granulators.com