

G 25

Granulators

Mod. G25-30

Mod. G25-45

Caratteristiche tecniche

- Realizzati per applicazioni bordopressa (iniezione, soffiaggio ed estrusione) e per usi generali.
- Quattro modelli base, disponibili in più di 36 versioni.
- Rotore con lame rotanti regolabili.
- Dischi laterali che ruotano assieme al rotore.
- Motore e quadro elettrico IP55.
- Apertura rapida e facilità di pulizia.
- Bassa rumorosità, ampiamente entro la norma EN 12012-1 appendice A.
- Vari sistemi di raccolta granulo disponibili, per le esigenze del cliente.



Technical data

- Designed for beside the press operation (injection, blow moulding and extrusion) and general purpose operation
- Four standard models, over 36 versions available.
- Rotor with adjustable rotating knives.
- Lateral end discs which turn with the rotor.
- IP55 control cabinet and electrical motor.
- Quick opening and easy cleaning.
- Noise level largely within European norms EN 12012-1 appendix A.
- A range of discharge systems are available to meet customers requirements.



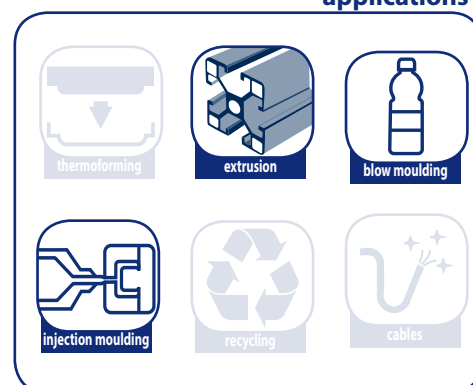

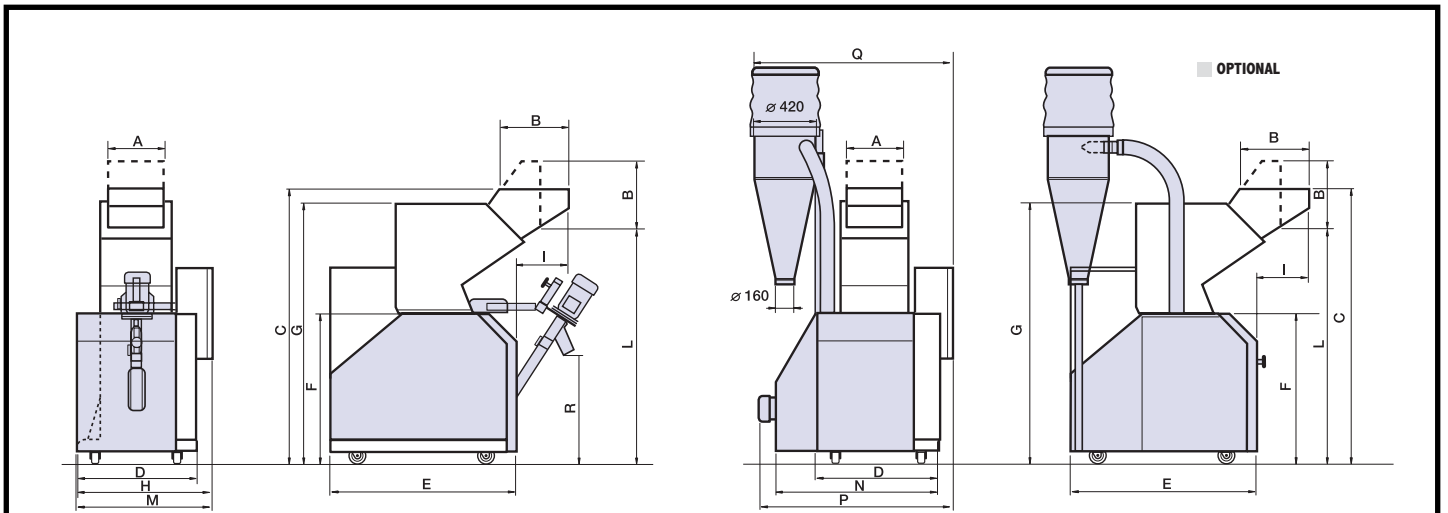



applications





	A	B	C	D	E	F	G	H	I	L	M	N	R	P	Q
G25-30	311	380	1530	660	1035	835	1460	735	283	1315	740	875	620	1045	1087
G25-45	457	380	1530	805	1035	835	1460	880	283	1315	885	1020	620	1190	1232



	 mm	 n°	 n°	 mm	 RPM	 KW	 Ø mm	 Kg/H
G25-30	380x311	3	2	250	340 (450-180)	4 (5,5)	8	80-140
G25-45	380x457	3	2	250	340 (450-180)	5,5 (7,5)	8	120-200



cmg-granulators.com