

# G 17

## Granulators

**Mod. G17-22**

**Mod. G17-38**



### Caratteristiche tecniche

- Realizzati per applicazioni bordopressa (iniezione e soffiaggio).
- Quattro modelli base, disponibili in più di 30 versioni.
- Disponibili con rotore aperto o con rotore a settori.
- Basso numero di giri del rotore (155 o 275 RPM).
- Griglia in acciaio Inox.
- Motore e quadro elettrico IP55.
- Apertura rapida e facilità di pulizia.
- Rumorosità ampiamente entro la norma EN 12012-1.

### Technical data

- Designed for beside the press operation (injection and blow moulding).
- Four standard models, over 30 versions available.
- Available with open rotor or with staggered rotor.
- Slow rotor speed (155 or 275 RPM).
- Standard screen in stainless steel.
- IP55 control cabinet and electrical motor.
- Quick opening and easy cleaning.
- Noise level largely within European norms EN 12012-1.

### applications





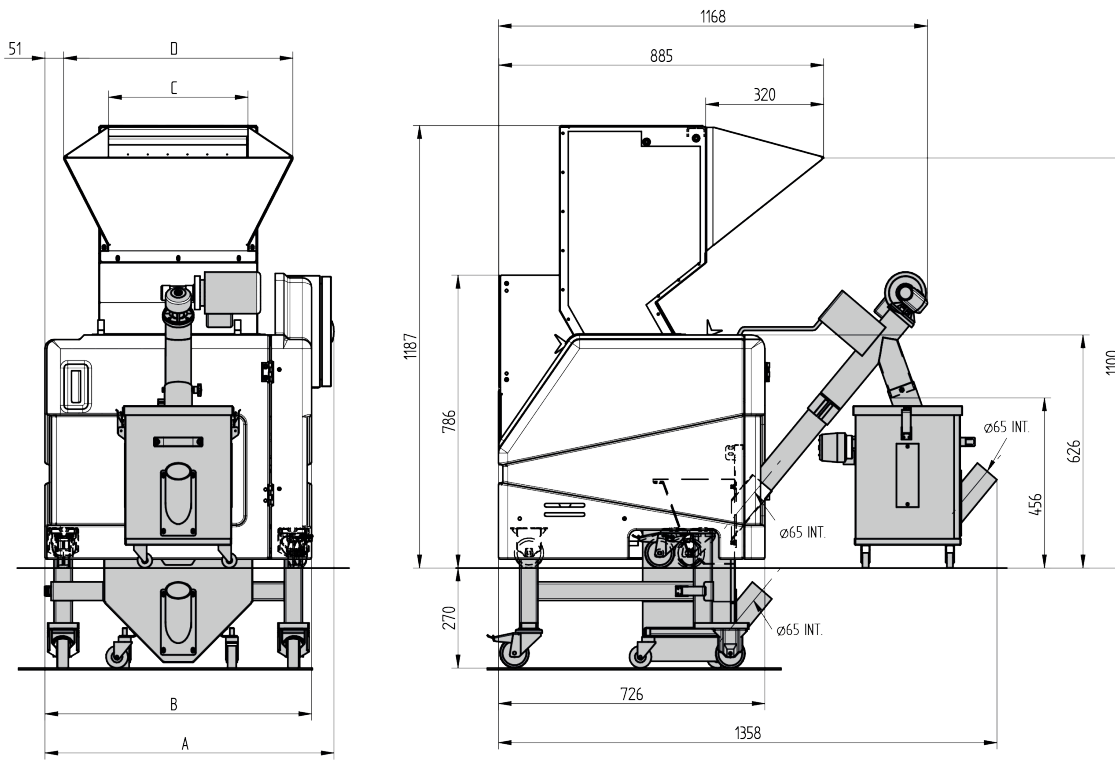



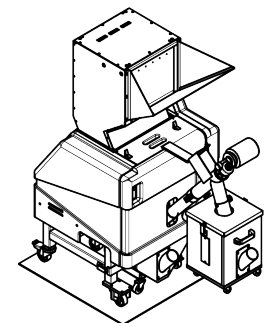

[cmg-granulators.com](http://cmg-granulators.com)



	A	B	C	D
<b>G17-22</b>	675	575	230	475
<b>G17-38</b>	825	725	380	625



	 mm	 n°	 n°	 mm	 RPM	 KW	 Ø mm	 Kg/H
<b>G17-22</b>	230 x 310	9 (3)	2	170	155(275)	2,2 (3,0-4,0)	5	30-50
<b>G17-38</b>	380 x 310	15 (3)	2	170	155(275)	2,2 (3,0-4,0)	5	50-90