

BG 17

Granulators

Mod. BG17-22

Mod. BG17-38

Caratteristiche tecniche

- Realizzati per applicazioni bordopressa (iniezione e soffiaggio)
- Rotore aperto 3k
- Basso numero di giri del rotore (280 G/MIN)
- Griglia in acciaio Inox
- Apertura rapida e facilità di pulizia



Technical data

- Designed for beside the press operation (injection and blow moulding)
- 3 knives open rotor
- Slow rotor speed (280 RPM)
- Standard screen in stainless steel
- Quick opening and easy cleaning





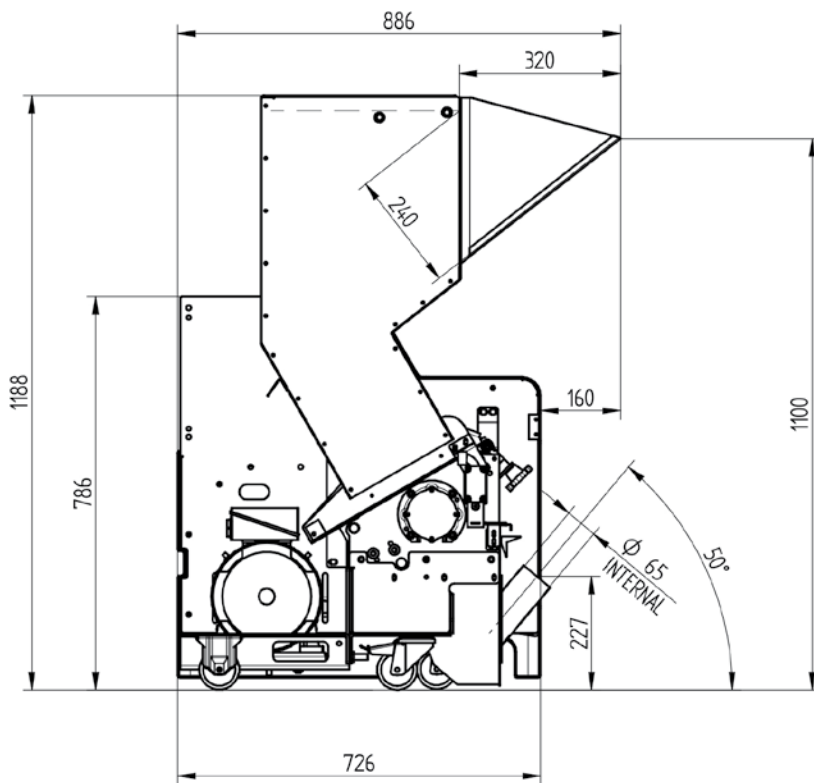
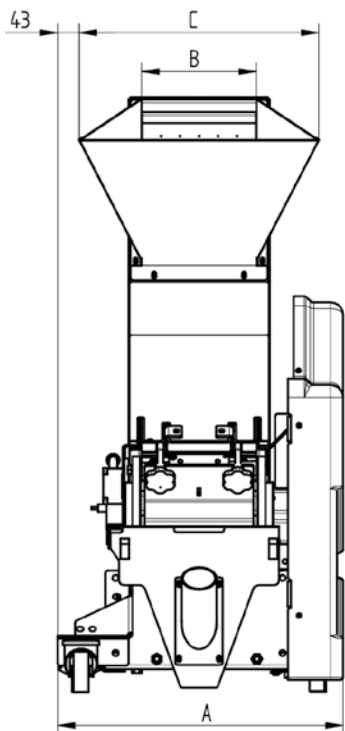



applications





	A	B	C
BG17-22	570	230	475
BG17-38	720	380	625



	 mm	 n°	 n°	 mm	 RPM	 KW	 Ø mm	 Kg/H
BG17-22	320x230	3	2	170	280	2,2	5	30-50
BG17-38	320x380	3	2	170	280	2,2	5	50-90



cmg-granulators.com