

B series

Granulators

Mod. B30-50-3K

Mod. B40-70-3K

Mod. B40-90-3K-TS

Caratteristiche tecniche

- Idonei per iniezione, soffiaggio, estrusione e per usi generali.
- Quattro modelli base disponibili.
- Tramoggia ribaltabile manualmente per una facile pulizia e manutenzione.
- Taglio a "doppia inclinazione", per ridurre il consumo di energia e la formazione di calore.
- Sicurezze conformi alle normative CE.



Technical data

- Suitable for injection & blow moulding, extrusion and general purpose applications.
- Four basic models.
- Tilting hopper manually operated for easier cleaning and maintenance.
- Advanced "Scissor" cutting action, reduces energy consumption, heat and dust generation.
- Safety complies with CE standard.

applications



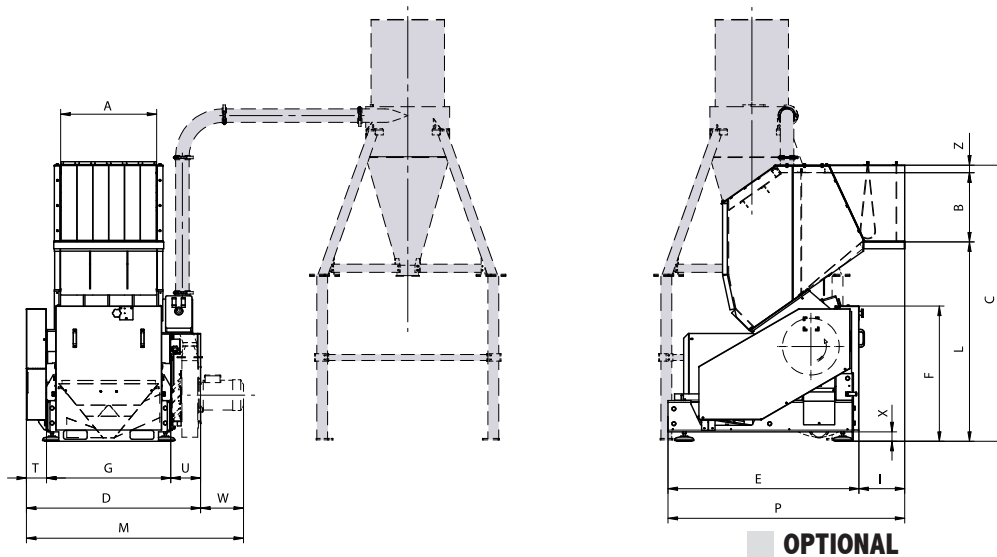









OPTIONAL

	A	B	C	D	E	F	G	I	L	M	P	T	U	W	X	Z
B30-50	510	310	1705	1017	1085	864	849	29	1353	1481	1114	119	49	470	90	42
B40-70	712	510	2042	1286	1410	1000	918	339	1475	1603	1749	148	220	317	70	56
B40-90	915	510	2042	1489	1410	1000	1121	339	1475	1806	1749	148	220	317	70	56



	 mm	 n°	 n°	 mm	 RPM	 Ø mm	 Kg/H	 KW
B30-50	310x510	3	2	305	450	8	250-340	11
B40-70	500x712	3 (5)	2	419	450	8	350-500	22
B40-90	500x915	3 (5)	2	419	450	8	500-700	30